

High Pressure HP03 Pattern Sandwich Accessory Valves

VSW SERIES 5 gpm (19 L/min) nominal 10 000 psi (700 bar)

VSW Series accessory valves operate at pressures to 10 000 psi (700 bar). They are used with Dynex high pressure VST and 6500 Series control valves which use the HP03 mounting interface.

These sandwich valves install under directional controls to provide a simpler compact assembly. They save space, reduce weight and provide greater flexibility in locating valves.

This modular circuit design requires less piping and fittings, reducing machine costs and assembly time. Direct mounting also limits potential system leakage.

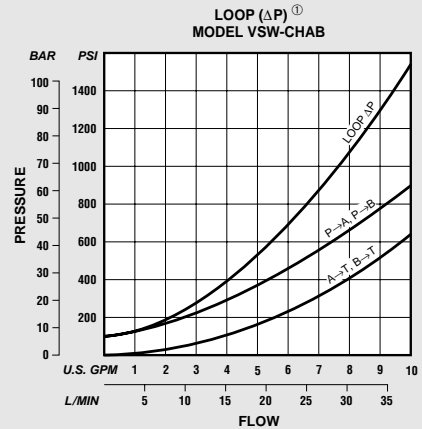
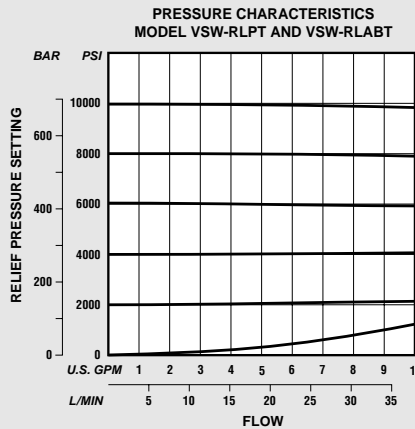

① Loop ΔP is the combined pressure drop through the valve ($P \rightarrow A + B \rightarrow T$ or $P \rightarrow B + A \rightarrow T$)

SPECIFICATIONS

Mounting

Special HP03 mounting interface

Functions

Model VSW-RLPT-HP03-10:

P \rightarrow T Relief;

Model VSW-RLABT-HP03-10:

A, B \rightarrow T Relief

Model VSW-CHAB-HP03-20:

Dual Pilot Operated Check;

Ratio to open the valve is approximately 7:1 at 10 000 psi (700 bar).

The valve will unseat when internal pilot pressure reaches about 14% (1/7) of the load pressure.

Rated Pressure

10 000 psi (700 bar)

Flow

Model VSW-RLPT and
Model VSW-RLABT:

5 gpm (19 L/min) nominal;
10 gpm (38 L/min) maximum;
0.5 gpm (1,9 L/min) minimum

Model VSW-CHAB:

5 gpm (19 L/min) nominal;
8 gpm (30 L/min) maximum;
No minimum flow.

Seals

Standard o-rings are fluorocarbon (Viton® or Fluorel®) providing greater fluid compatibility and improved temperature performance.

Optional seals include Buna-N or EPR for use with some phosphate ester fluids. Contact the Dynex sales department for complete ordering information.

Installation And Dimensions

DIMENSIONS

Dimensions are shown in inches (millimeters in parentheses) and are nominal.

The mounting surface drawing shows the minimum flush or raised surface required for the special HP03 pattern.

Mounting face must be flat within 0.0004 inch/4.0 inches (0,010 mm/102 mm) with a surface finish of 32 microinch (0,80 μ m) AA.

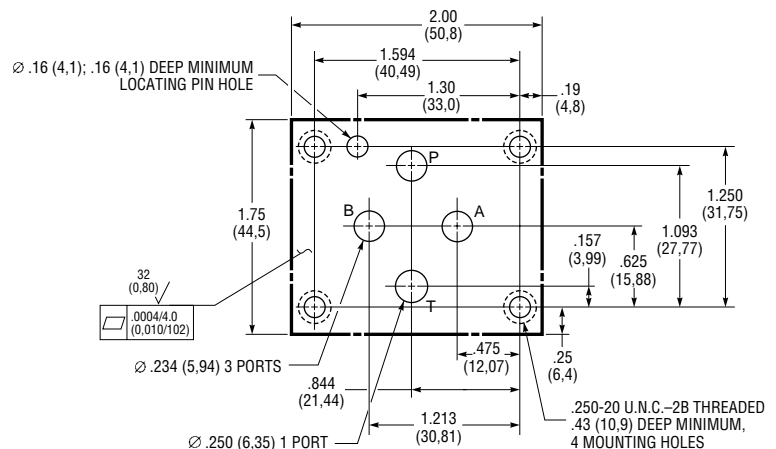

Minimum Mounting Surface, Special HP03 Pattern

MOUNTING

Port o-rings are included with valves. Mounting bolts must be ordered separately.

Subplates are available for mounting on the HP03 pattern. Mounting bolts are supplied as part of the subplate kit. When ordering valves and subplates together, valves are not mounted on subplate.

BOLT KITS

Item (Part Number)	Description
Bolt Kit (P11-BK-44)	For mounting one VSW-RL** on 6500 Series (HP03 pattern) valve: (4) .250-20 U.N.C. Threaded x 2.75 inches (69,8 mm) long
Bolt Kit (P11-BK-64)	For mounting one VSW-RL** on VST Series (HP03 pattern) valve: (4) .250-20 U.N.C. Threaded x 4.00 inches (101,6 mm) long
Bolt Kit (P11-BK-36)	For mounting one VSW-CHAB on 6500 Series (HP03 pattern) valve: (4) .250-20 U.N.C. Threaded x 2.25 inches (57,2 mm) long
Bolt Kit (P11-BK-56)	For mounting one VSW-CHAB on VST Series (HP03 pattern) valve: (4) .250-20 U.N.C. Threaded x 3.50 inches (88,9 mm) long

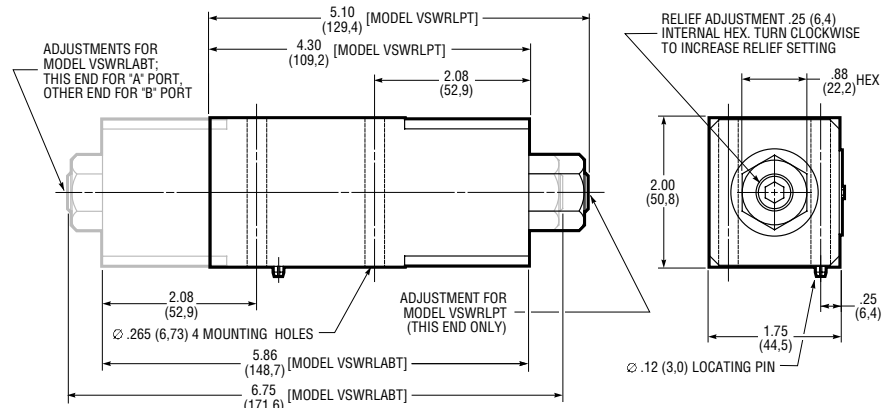

Model VSW-RLPT-HP03-10 (P→T Relief Valve) and Model VSW-RLABT-HP03-10 (A,B→T Relief Valve), Shown Printed in Gray

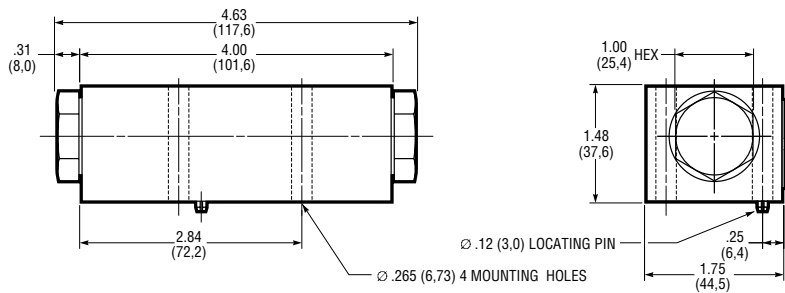

Model VSW-CHAB-HP03-20 (Dual Pilot Operated Check Valve)

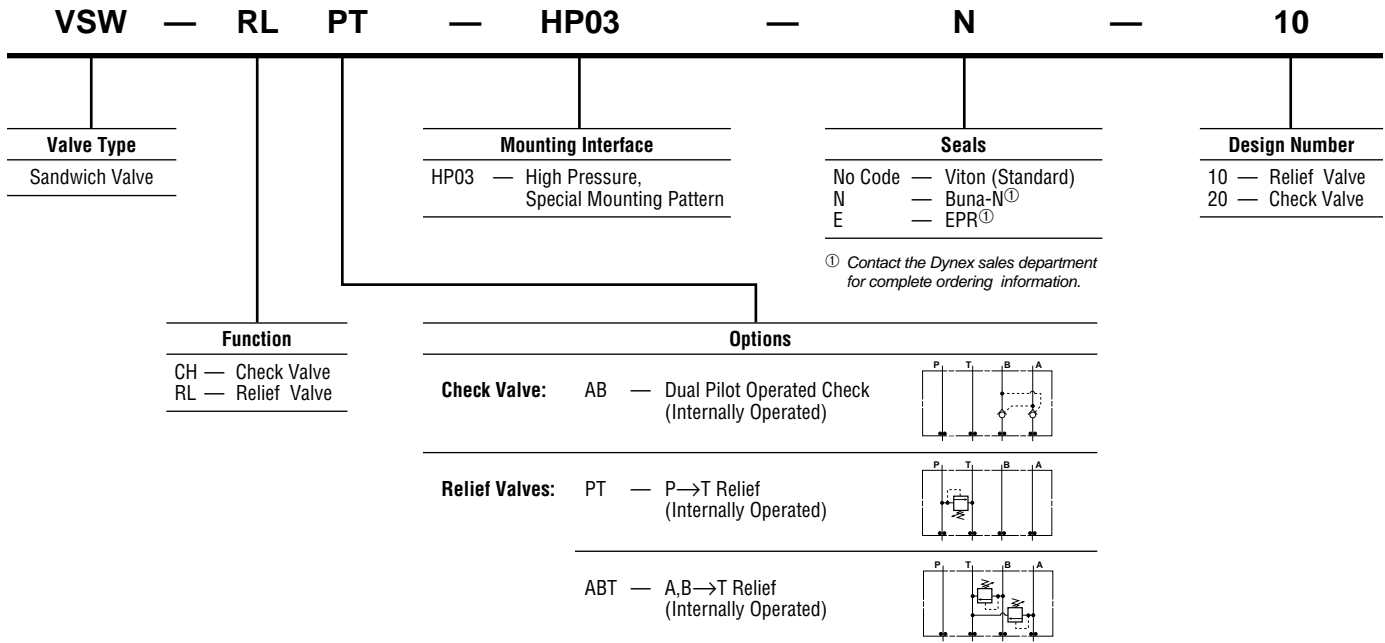

USA Headquarters

Dynex/Rivett Inc.
770 Capitol Drive
Pewaukee, WI 53072 U.S.A.
Tel: (262) 691-2222
FAX: 262-691-0312
E-mail: sales@dynexhydraulics.com
Web Site: www.dynexhydraulics.com

Power Units & Systems

Dynex/Rivett Inc.
54 Nickerson Road
Ashland, MA 01721 U.S.A.
Tel: (508) 881-5110
FAX: 508-881-6849
E-mail: ashland@dynexhydraulics.com

European Sales

Dynex/Rivett Inc.
Unit C5 Steel Close, Little End Road,
Eaton Socon, Huntingdon,
Cambs. PE19 8TT United Kingdom
Tel: +44 (0) 1480 213980
FAX: +44 (0) 1480 405662
E-mail: sales@dynexhydraulics.co.uk