

Pressure Compensated Checkball Piston Pumps

Also refer to "Checkball Pump Installation and Operating Recommendations" Bulletin PSI.CB ([dynexpumpinstallation.pdf](#))

CONTACT INFORMATION

USA Headquarters

Dynex/Rivett Inc.
770 Capitol Drive
Pewaukee, WI 53072 U.S.A.
Tel: 262-691-2222
FAX: 262-691-0312
E-mail: sales@dynexhydraulics.com

Power Units & Systems

Dynex/Rivett Inc.
54 Nickerson Road
Ashland, MA 01721 U.S.A.
Tel: 508-881-5110
FAX: 508-881-6849
E-mail: ashland@dynexhydraulics.com

European Sales

Dynex/Rivett Inc.
Unit C5 Steel Close, Little End Road, Eaton Socon,
Huntingdon, Cambs. PE19 8TT United Kingdom
Tel: +44 (0) 1480 213980
FAX: +44 (0) 1480 405662
E-mail: sales@dynexhydraulics.co.uk

Download Dynex Product Specifications!

www.dynexhydraulics.com



BROCHURE NOTES:

Specifications shown were in effect when published. Since errors or omissions are possible, contact your sales representative or the sales department for the most current specifications before ordering. Dynex reserves the right to discontinue products or change designs at any time without incurring any obligation.



PV4000 PRESSURE COMPENSATED



PUMP DESCRIPTION

These high-pressure checkball pumps adjust their output flow to maintain a preset maximum pressure.

The integral pressure compensator overrides a maximum volume control to smoothly and quietly regulate delivery. Fast response to load conditions assures full power in the system up to a pressure very close to the compensator setting.

These mechanically controlled pumps are not bi-rotational; rotation must be specified, viewed from the shaft end.

Electrohydraulic Remote Control

Electrohydraulic flow control can be achieved using a Dynex Remote Proportional Actuator (RPA). The bracket-mounted actuator strokes the pump volume control stem. See page 4.

For complete RPA specifications, refer to Bulletin EES.RPA.

Mounting

S.A.E. D 4-bolt pattern with 0.25 inch (6,4 mm) pilot engagement.

Shaft

Standard keyed shaft, 1.250 inch (31,75 mm) diameter;

Outlet Port Options

Standard S.A.E. ports. See "Outlet Port Configurations" on page 9.

Inlet Conditions

Pumps may require pressurized inlet conditions at higher speeds. Failure to meet minimum inlet requirements will result in slight flow reduction. Refer to the table.

Specifications

Pump Models	Output Flow at 1500 rpm ^①		Output Flow at 1800 rpm ^①		Rated Pressure		Maximum Intermittent Pressure		Rated Speed rpm	Maximum Speed rpm
	U.S. gpm	L/min	U.S. gpm	L/min	psi	bar	psi	bar		
<i>Pressure Compensated with Volume Stem Control:</i>										
PV4020-3046	9.8	37,1	12.0	45,4	8000 ^②	560	8500 ^②	590	1800	1800
PV4026-3126	14.7	55,6	17.6	66,6	4000	280	6000	420	1800	1800
PV4033-3127	18.7	70,8	22.4	84,8	4000	280	6000	420	1800	1800
<i>Pressure Compensated with Electrohydraulic Control:</i>										
PV4020-3187	9.8	37,1	12.0	45,4	8000 ^②	560	8500 ^②	590	1800	1800
PV4026-3188	14.7	55,6	17.6	66,6	4000	280	6000	420	1800	1800
PV4033-3189	18.7	70,8	22.4	84,8	4000	280	6000	420	1800	1800

① Output flow based on typical performance at rated pressure with pressurized inlet where required, as shown in the table below.

② The pressure rating may be limited by the fitting used in the No. 12 S.A.E. outlet port. Contact the fitting manufacturer for the pressure rating of the fitting.

Minimum Inlet Pressures^①

Pump Models	Operating Speed					
	1200 rpm		1500 rpm		1800 rpm	
	psi	bar	psi	bar	psi	bar
All PV4000 Pressure Compensated Models	0	0	5	0,4	5	0,4

① Values shown are based on fluid viscosity of 100 SUS (20 cSt). Inlet pressures higher than 10 psig (0,7 bar) require a high-pressure shaft seal.

Seal Options

Standard seals are Buna-N (Nitrile). Options include Fluorocarbon (Viton® or Fluorel®) or EPR for use with some phosphate ester fluids.

Weight (Mass)

Manual Control Models:
140 lb (64 kg)

Electrohydraulic Control Models:
156 lb (71 kg)

PUMP SELECTION

The "Specifications" table includes the most commonly used standard models with keyed shafts.

Models listed are for clockwise rotation. These compensated pumps deliver full flow with the volume stem control in the "out", fully-extended position.

Contact the sales department for models with optional seals, counter-clockwise rotation, different control options and other extraordinary operating requirements.

Maximum Pressure

Checkball pumps are especially suited for applications susceptible to excessive pressure spikes.

The intermittent pressures listed are the maximum pressures a pump can sustain for occasional, short periods of operation without appreciably reducing life expectancy.

Fluid Guidelines

See page 8 for "Fluid Recommendations".

Some pump models may require reduced operating pressures when using low-lubricity fluids.

Because of the wide range of fluid characteristics, contact the sales department for a review of any application using non-petroleum based fluids.

PV4000 PRESSURE COMPENSATED

Typical Performance Curves

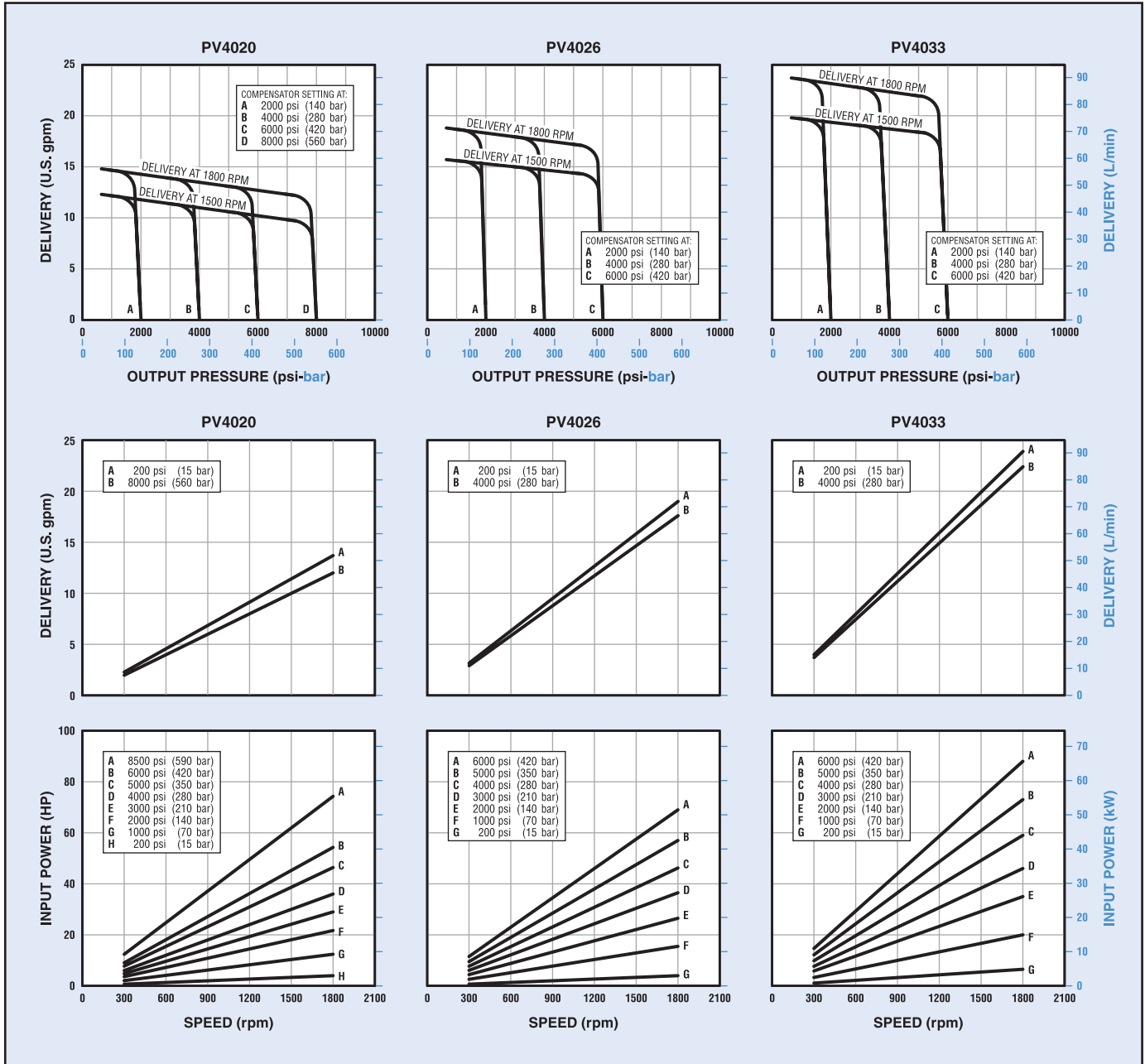

Typical performance curves are based on 100 SUS (20 cSt) mineral oil with pressurized inlet where required. Refer to "Minimum Inlet Pressure" table on page 2.

PV4000 PRESSURE COMPENSATED

INSTALLATION

All dimensions are shown in inches (millimeters in parentheses) and are nominal.

Refer to Bulletin PSI.CB for general installation and operating recommendations.

Volume and Pressure Control

Compensated models deliver full flow with the volume control stem extended out of the pump.

Pressure is set by turning the adjustment clockwise for increased pressure. One-quarter turn equals 1000 psi (70 bar). The adjustment range is 1000 psi (70 bar) to the maximum pressure rating. Maximum torque required to adjust the compensator is 20 lb·in (2,3 N·m).

Pump Inlet/Drain Port

Note the location of the dual purpose inlet/drain port. Acting as an inlet, this port increases volumetric efficiency by improving the filling of the piston chamber.

Acting as a drain, the port diverts unused fluid at low pressure from the chamber, providing improved circulation which dissipates heat.

Electrohydraulic Pump Control

PV4000 Series pumps use a bracket-mounted Dynex Remote Proportional Actuator (RPA) to stroke the pump volume control stem.

Electrohydraulic capability can be added to a standard pump using an Electrohydraulic Control Kit. Refer to the table.

The RPA requires a separate pilot supply: Minimum, 200 psi (15 bar); Maximum, 3000 psi (210 bar). For complete RPA specifications, refer to Bulletin EES.RPA.

Assembly of RPA and Bracket

For ease of shipping, electrohydraulic models are shipped as two sub-assemblies. The RPA/bracket sub-assembly must be mounted to the rear of the pump using the tie rods and nuts provided with the pump. Recommended torque is 40 lb·ft (54 N·m).

Electrohydraulic Control Kits

Pump	Kit Number ^①
<i>PV4000 Series Pumps:</i>	
Pressure Compensated	KP4020-9047
Non-compensated	KP4026-9047

^① Kit includes a bracket and hardware. The Dynex Remote Proportional Actuator must be ordered separately.

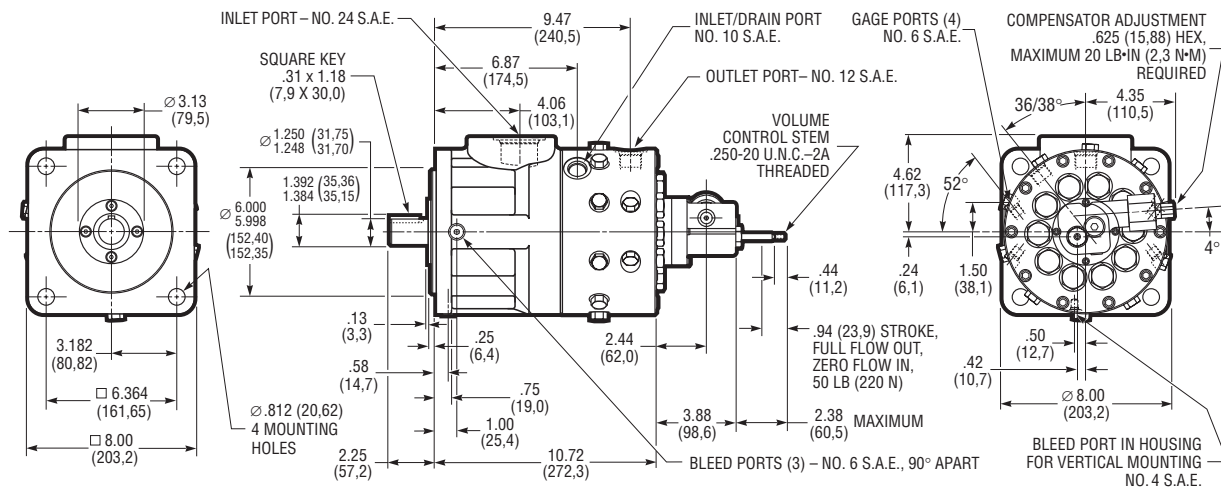

Manual Volume Control Pressure Compensated Models

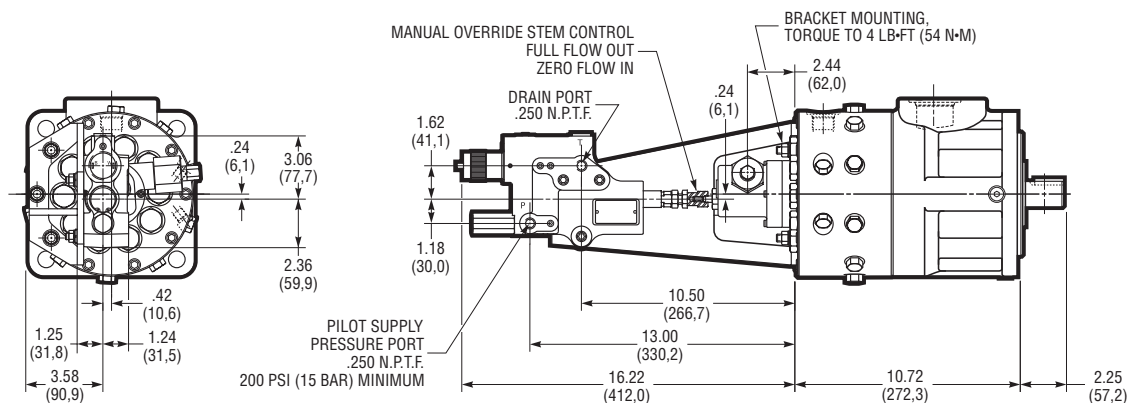

Electrohydraulic Volume Control Pressure Compensated Models

PV6000 PRESSURE COMPENSATED

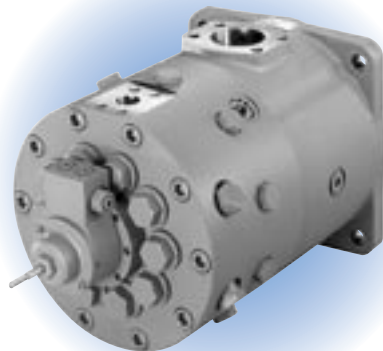

PUMP DESCRIPTION

These high-pressure checkball pumps adjust their output flow to maintain a preset maximum pressure.

The integral pressure compensator overrides a maximum volume control to smoothly and quietly regulate delivery. Fast response to load conditions assures full power in the system up to a pressure very close to the compensator setting.

These mechanically controlled pumps are not bi-rotational; rotation must be specified, viewed from the shaft end.

Electrohydraulic Remote Control

Electrohydraulic flow control can be achieved using a Dynex Remote Proportional Actuator (RPA). The bracket-mounted actuator strokes the pump volume control stem.

Electrohydraulic control is not available for PV6000 Series as an integral unit. Refer to page 7 for information on the Electrohydraulic kit.

For complete RPA specifications, refer to Bulletin EES.RPA.

Mounting

S.A.E. E 4-bolt pattern with 0.25 inch (6,4 mm) pilot engagement.

Standard Spline Shaft

1.748/1.747 inch diameter standard 13 tooth, 8/16 D.P. 30° involute spline.

Specifications

Pump Models	Output Flow at 1500 rpm ^①		Output Flow at 1800 rpm ^①		Rated Pressure		Maximum Intermittent Pressure		Rated Speed rpm	Maximum Speed rpm
	U.S. gpm	L/min	U.S. gpm	L/min	psi	bar	psi	bar		
<i>Pressure Compensated with Volume Stem Control:</i>										
PV6046-3177	25.9	98,1	31.1	117,7	6000	420	8500	590	1800	1800
PV6054-3183	30.5	115,5	36.7	138,9	6000	420	8500	590	1800	1800
PV6070-3502	40.0	151,4	48.0	181,7	6000	420	8500	590	1800	1800
PV6089-3498	51.2	193,8	61.4	232,4	6000	420	6000 ^②	420 ^②	1800	1800

^① Output flow based on typical performance at rated pressure with pressurized inlet where required, as shown in the table below.

^② For applications requiring intermittent operation above 6000 psi (420 bar), contact the sales department.

Minimum Inlet Pressures^①

Pump Models	Operating Speed					
	1200 rpm		1500 rpm		1800 rpm	
	psi	bar	psi	bar	psi	bar
PV6046 and PV6054	0	0	3	0,2	5	0,4
PV6070	3	0,2	8	0,6	10	0,7
PV6089	5	0,4	10	0,7	15	1,0

^① Values shown are based on fluid viscosity of 100 SUS (20 cSt). All PV6000 Series pumps have a high-pressure shaft seal.

Outlet Port

As shown, the standard S.A.E. No. 16 outlet port on these pumps is machined in a block integrally mounted to the pump barrel. See "Outlet Port Configurations" on page 9.

Inlet Conditions

Pumps may require pressurized inlet conditions at higher speeds. Failure to meet minimum inlet requirements will result in slight flow reduction. Refer to the table.

Seal Options

Standard seals are Fluorocarbon (Viton® or Fluorel®). All PV6000 Series pumps have a high-pressure shaft seal. Options include EPR seals for use with some phosphate ester fluids.

Weight (Mass)

Models PV6046, PV6054 and PV6070:
345 lb (156 kg)

Model PV6089:
360 lb (163 kg)

PUMP SELECTION

The "Specifications" table includes the most commonly used standard models with spline shafts.

Models listed are for clockwise rotation. These compensated pumps deliver full flow with the volume stem control in the "out", fully-extended position.

Contact the sales department for models with optional seals, counter-clockwise rotation, handwheel control option and other extraordinary operating requirements.

Fluid Guidelines

See page 8 for "Fluid Recommendations". Some pump models may require reduced operating pressures when using low-lubricity fluids.

Because of the wide range of fluid characteristics, contact the sales department for a review of any application using non-petroleum based fluids.

PV6000 PRESSURE COMPENSATED

Typical Performance Curves

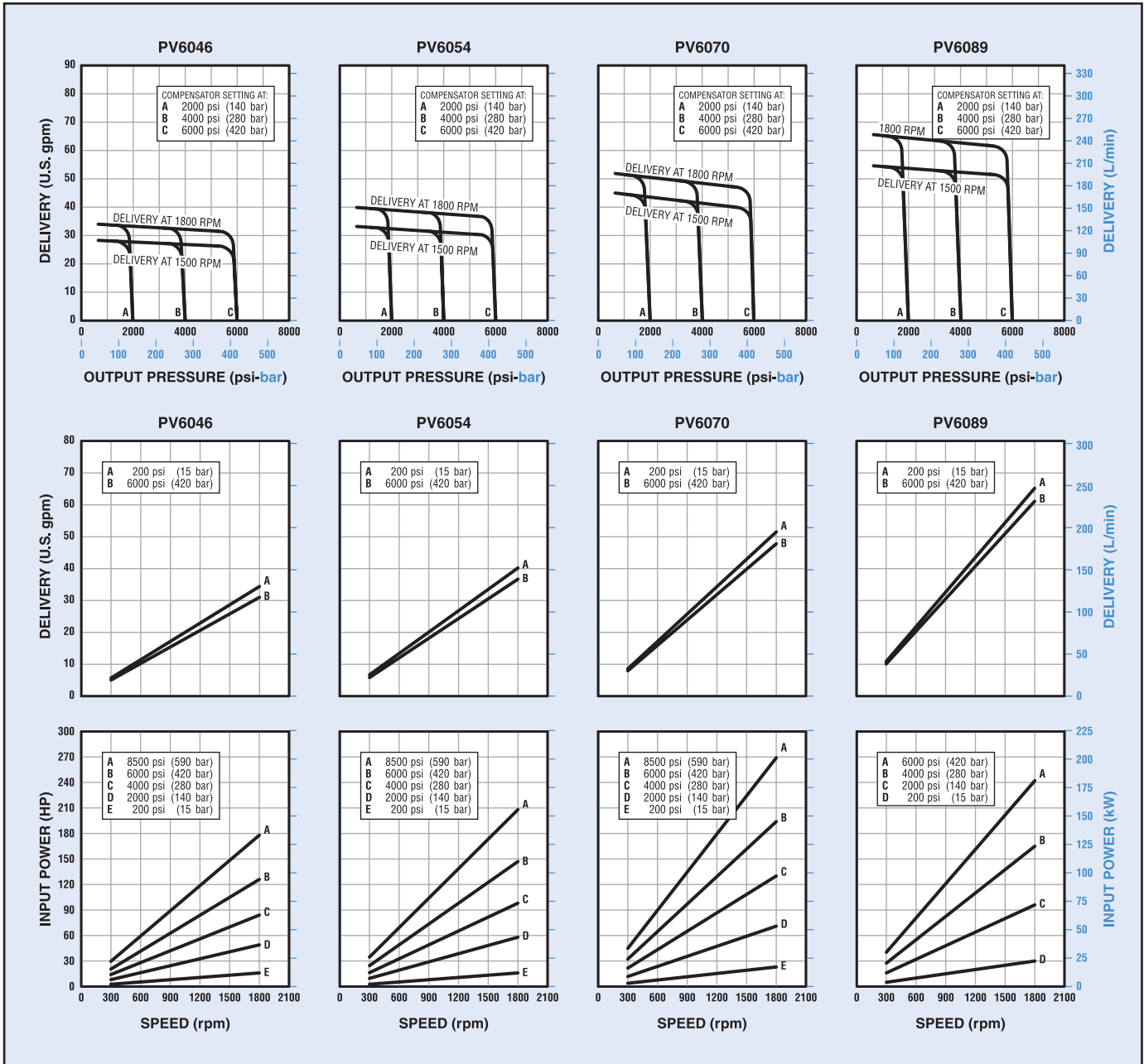

Typical performance curves are based on 100 SUS (20 cSt) mineral oil with pressurized inlet where required. Refer to "Minimum Inlet Pressure" table on page 5.

PV6000 PRESSURE COMPENSATED

INSTALLATION

All dimensions are shown in inches (millimeters in parentheses) and are nominal.

Refer to Bulletin PSI.CB for general installation and operating recommendations.

Volume and Pressure Control

Compensated models deliver full flow with the volume control stem extended out of the pump.

Pressure is increased by turning the adjustment clockwise. One-quarter turn equals 1000 psi (70 bar), with a range from

1000 psi (70 bar) to the maximum pressure rating. Maximum torque required to adjust the compensator is 30 lb·in (3,4 N·m).

Pump Inlet/Drain Port

Note the location of the dual purpose inlet/drain port. Acting as an inlet, this port increases volumetric efficiency by improving the filling of the piston chamber.

Acting as a drain, the port diverts unused fluid at low pressure from the chamber, providing improved circulation which dissipates heat.

Electrohydraulic Remote Control

Electrohydraulic flow control can be achieved using a Dynex Remote Proportional Actuator (RPA) to stroke the volume control stem.

Electrohydraulic capability can be added using Kit KP6046-9047, which includes a bracket and hardware. The RPA must be ordered separately.

The RPA requires a separate pilot supply: Minimum, 200 psi (15 bar); Maximum, 3000 psi (210 bar). For complete RPA specifications, refer to Bulletin EES.RPA.

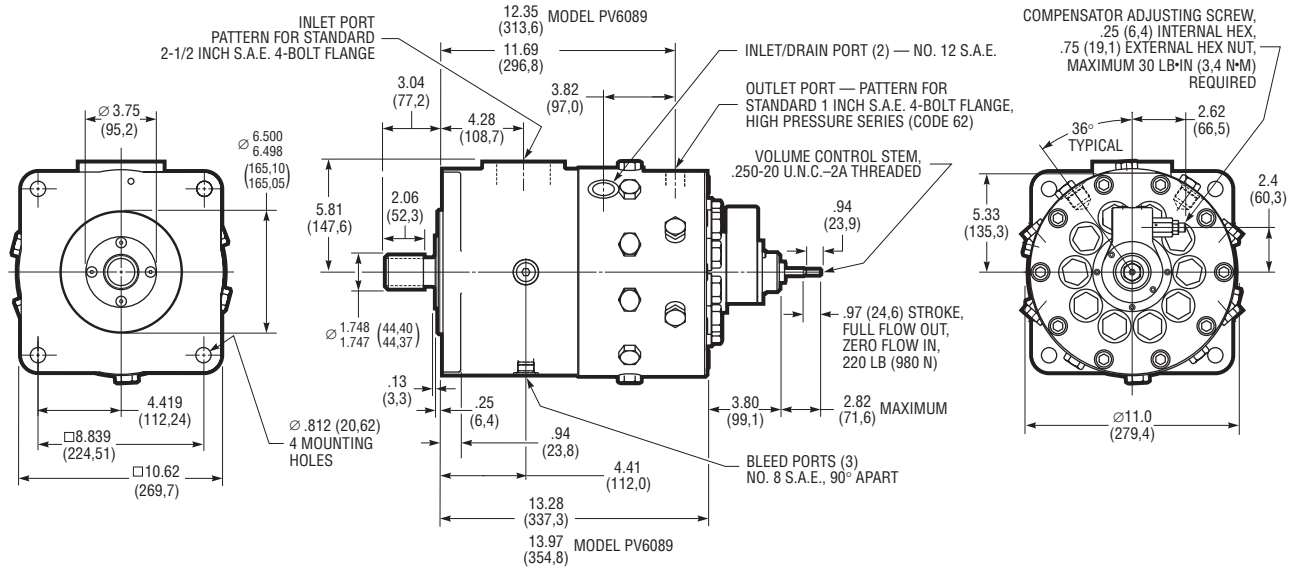

FLUID RECOMMENDATIONS

Mineral Oil

A high-grade premium petroleum-based fluid should be used to assure long component and system life. The fluid should have a combination of anti-wear, demulsibility, rust protection, oxidation-resistant and foam-resistant properties.

Special Fluids

Various pump models are available for use with water-based fluids, diesel calibration fluids, phosphate ester fluids, machining coolant, brake fluid, various military fluids and other special fluids.

PF4300 Series pumps are compatible with a variety of water-based fluids. These models, which are specifically rated for use with low-lubricity fluids.

Some pump models may require reduced operating pressures when using low-lubricity fluids.

Because of the wide range of fluid characteristics, contact the sales department for a review of any application using non-petroleum based fluids.

Viscosity Specifications

Using fluid with the correct viscosity range is critical to achieving long component life.

Fluid conditions outside the "Optimum" range shown in the table may result in reduced pump output, requiring pressurized inlet conditions. For more information, contact the sales department.

Hydraulic Fluid Viscosity^①

Pump Models	Operating				Start-up ^②		Optimum		
	Minimum		Maximum		SUS	cSt	SUS	cSt	
	SUS	cSt	SUS	cSt					
<i>Fixed Displacement Pumps:</i>									
PF500-10	52	8	1911	413	3706	800	98 to 324	20 to 70	
PF1000-10	59	10	1911	413	3706	800	98 to 324	20 to 70	
PF2000	59	10	1911	413	1911	413	98 to 324	20 to 70	
PF2000 ^②	34	2,3	1911	413	1911	413	98 to 324	20 to 70	
PF3000-10	59	10	1911	413	3706	800	98 to 342	20 to 70	
PF4000-30	34	2,3	1911	413	1911	413	98 to 324	20 to 70	
PF4200-10	34	2,3	1911	413	1911	413	98 to 324	20 to 70	
PF4300-11	31	1,5	927	200	927	200	–	–	
PF6000	34	2,3	1911	413	1911	413	98 to 324	20 to 70	
<i>Mechanical Variable Delivery Pumps:</i>									
PV4000	34	2,3	1911	413	1911	413	98 to 324	20 to 70	
PV6000	34	2,3	1911	413	1911	413	98 to 324	20 to 70	
<i>Hydraulic Variable Delivery Pumps:</i>									
PV6000	34	2,3	1911	413	1911	413	98 to 324	20 to 70	

① Fluid conditions outside the "Optimum" range may result in reduced output, requiring pressurized inlet conditions. Contact the sales department.

② Models with special mounting.

MINIMUM FILTRATION LEVELS

Pump inlet: 150 μ nominal;

Pressure or return line: 25 μ nominal.

While finer filtration levels than these are desirable and will result in longer component life, restricting flow to the pump inlet should be avoided. Minimum recommended inlet conditions must be maintained.

If a system component fails resulting in fluid contamination, it is important to drain and clean the reservoir, all lines, filter screens and all components. Refill with new fluid.

INSTALLATION AND OPERATION

Refer to separate Bulletin PSI.CB for general installation and operating recommendations.

That brochure includes information on mounting, shaft loading, sizing inlet pipe and hose, air bleed procedures and initial start-up. Guidelines for maintenance, repair and trouble-shooting are also included.

PORT DESCRIPTIONS

Dynex pumps are available with outlet ports suitable for use at various pressure ranges. Refer to the appropriate "Specification Table" or "Typical Model Code" to specify the required port.

Contact the fitting manufacturer to ensure the selected fittings are rated for the maximum pump operating pressure.

S.A.E. Straight Thread Ports

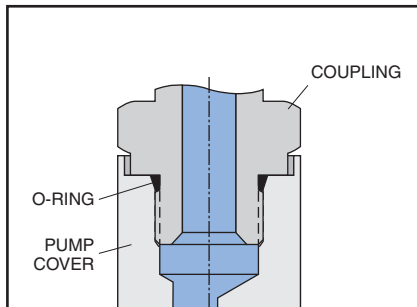

Typical S.A.E. Straight Thread port connection

The Straight Thread connection (S.A.E. J1926/1) is sometimes referred to as an S.A.E. O-ring Boss, or ORB. The port consists of a machined spotface surface, a tapered seal cavity and a straight thread port.

The fitting forms a seal by compressing the o-ring in the seal cavity with the underside of the flanged wrench flat. Some adjustable fittings, such as elbows and tees, use a locknut with a captive backup washer for compression.

S.A.E. Straight Thread ports are not recommended for operation above 8000 psi (560 bar). Also, the maximum pressure of pumps with No. 12 S.A.E. outlet ports may be limited by the pressure rating of the available fitting. Contact the fitting manufacturer for ratings.

Coned and Threaded Ports

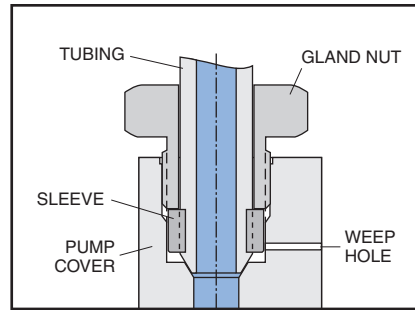

Typical Coned and Threaded port connection

High-pressure pumps are available with coned and threaded outlet ports, which use Autoclave Medium Pressure, Butech M/P, or equivalent fittings.

These fittings provide a metal-to-metal seal with an interference fit, not requiring an o-ring. The gland nut holds the sleeve and tubing against the cone surface.

A weep hole, visible on the outside of the pump cover, acts as an indicator of any abnormal leakage caused by system conditions (i.e., excessive pressure). It allows any fluid which does leak past the sealing surfaces to escape, preventing pressure build-up and possible damage.

British Standard Pipe Ports

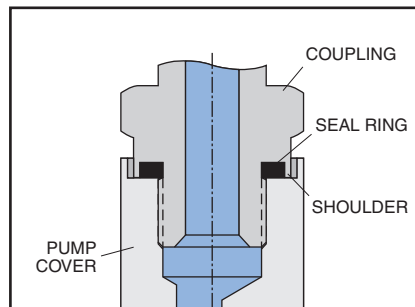

Typical port connection with British Standard Pipe (Parallel) fitting with shoulder

High-pressure pumps are available with flat face ports with British Standard Pipe (B.S.P.) parallel threads (BS 2779 or ISO 228), ideal for use on some European applications.

The fitting forms a seal by compressing a flat elastomer ring on a machined spotface surface. There are several sealing methods for these ports.

The recommended fitting has a recessed seal cavity formed by a shoulder on the underside of the flanged wrench flat (Voss "Peflex", Form B Shoulder Seal; or Parker Type E, "Elastic" Seal; or equivalent).

B.S.P. ports are not recommended for operation above 10 000 psi (700 bar). Contact the fitting manufacturer, to ensure the selected fittings are rated for the maximum pump operating pressure.

S.A.E. 4-Bolt Flange Ports

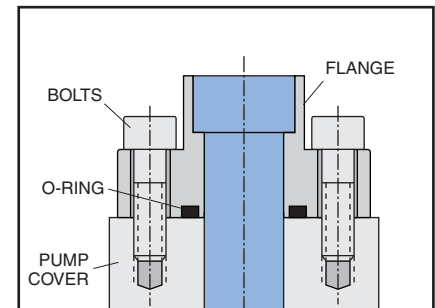

Typical S.A.E. 4-Bolt Flange port connection

Flange connections are often used for higher flows requiring larger diameter tubing. The port consists of an unthreaded port with four bolt holes in a rectangular pattern on a machined face around the port (S.A.E. J518).

A typical fitting consists of a flanged head with a welded tube and a captive flange with bolt holes. A seal is formed by an o-ring in the groove on the underside mounting surface of the flange head. As the flange bolts are alternately tightened, the o-ring is compressed between the flange head and the machined face on the pump.

To make mounting easier in tight spaces a two-piece split-flange is often used.