

PV4000 Series Mechanical Variable Pumps

Also refer to "Checkball Pump Installation and Operating Recommendations" Bulletin PSI.CB ([dynexpumpinstallation.pdf](#))

CONTACT INFORMATION

USA Headquarters

Dynex/Rivett Inc.
770 Capitol Drive
Pewaukee, WI 53072 U.S.A.
Tel: 262-691-2222
FAX: 262-691-0312
E-mail: sales@dynexhydraulics.com

Power Units & Systems

Dynex/Rivett Inc.
54 Nickerson Road
Ashland, MA 01721 U.S.A.
Tel: 508-881-5110
FAX: 508-881-6849
E-mail: ashland@dynexhydraulics.com

European Sales

Dynex/Rivett Inc.
Unit C5 Steel Close, Little End Road, Eaton Socon,
Huntingdon, Cambs. PE19 8TT United Kingdom
Tel: +44 (0) 1480 213980
FAX: +44 (0) 1480 405662
E-mail: sales@dynexhydraulics.co.uk

Download Dynex Product Specifications!

www.dynexhydraulics.com



BROCHURE NOTES:

Specifications shown were in effect when published. Since errors or omissions are possible, contact your sales representative or the sales department for the most current specifications before ordering. Dynex reserves the right to discontinue products or change designs at any time without incurring any obligation.



PV4000 SERIES



Specifications

| Pump Models | Output Flow at 1500 rpm ^① | | Output Flow at 1800 rpm ^① | | Rated Pressure | | Maximum Intermittent Pressure | | Rated Speed rpm | Maximum Speed rpm |
|-------------|--------------------------------------|-------|--------------------------------------|-------|----------------|-----|-------------------------------|-----|-----------------|-------------------|
| | U.S. gpm | L/min | U.S. gpm | L/min | psi | bar | psi | bar | | |
| PV4018-2928 | 10.1 | 38,2 | 12.2 | 46,2 | 4000 | 280 | 6000 | 420 | 2000 | 2400 |
| PV4026-2929 | 14.7 | 55,6 | 17.6 | 66,6 | 4000 | 280 | 6000 | 420 | 2000 | 2400 |
| PV4033-2117 | 18.7 | 70,8 | 22.4 | 84,8 | 4000 | 280 | 6000 | 420 | 1800 | 2100 |

^① Output flow based on typical performance at rated pressure with pressurized inlet where required, as shown in the table below.

PUMP DESCRIPTION

PV4000 Series checkball pumps supply infinitely variable flow. Output is regulated by mechanically controlled variable inlet ports in each piston pumping chamber.

Mechanical variable pumps are not bi-rotational; rotation must be specified, viewed from the shaft end.

Mounting

S.A.E. D 4-bolt pattern with 0.25 inch (6,4 mm) pilot engagement.

Shaft Options

Standard keyed shaft, 1.250 inch (31,75 mm) diameter;

Optional spline shaft, 1.248/1.247 inch diameter standard S.A.E. 14 tooth, 12/24 D.P. 30° involute spline.

Outlet Port

Standard S.A.E. ports. See "Outlet Port Configurations" on page 5.

Inlet Conditions

Pumps may require pressurized inlet conditions at higher speeds. Failure to meet minimum inlet requirements will result in slight flow reduction. Refer to the table.

Seal Options

Standard seals are Buna-N (Nitrile). Options include Fluorocarbon (Viton® or Fluorel®) or EPR for use with some phosphate ester fluids.

Inlet pressures higher than 10 psig (0,7 bar) require a high-pressure shaft seal.

Weight (Mass)

125 lb (57 kg)

Minimum Inlet Pressures^①

| Pump Models | Operating Speed | | | | | | | |
|-------------------|-----------------|-----|----------|-----|----------|-----|----------|-----|
| | 1200 rpm | | 1500 rpm | | 2100 rpm | | 2400 rpm | |
| | psi | bar | psi | bar | psi | bar | psi | bar |
| PV4018 and PV4026 | 0 | 0 | 5 | 0,4 | 5 | 0,4 | 10 | 0,7 |
| PV4033 | 0 | 0 | 5 | 0,4 | 5 | 0,4 | — | — |

^① Values shown are based on fluid viscosity of 100 SUS (20 cSt). Inlet pressures higher than 10 psig (0,7 bar) require a high-pressure shaft seal.

PUMP SELECTION

The "Specifications" table includes the most commonly used standard models with keyed shafts.

Models listed are for clockwise rotation and deliver zero flow with the volume stem control in the "out", fully-extended position. Models are also available to deliver full flow with the stem extended.

Contact the sales department for models with spline shafts, optional seals, counter-clockwise rotation, different control options and other extraordinary operating requirements.

Maximum Pressure

Checkball pumps are especially suited for applications susceptible to excessive pressure spikes.

The intermittent pressures listed are the maximum pressures a pump can sustain for occasional, short periods of operation without appreciably reducing life expectancy.

Fluid Guidelines

See page 4 for "Fluid Recommendations".

Some pump models may require reduced operating pressures when using low-lubricity fluids.

Because of the wide range of fluid characteristics, contact the sales department for a review of any application using non-petroleum based fluids.

Split-Flow® Provides Multiple Outlets

PV4000 models with split-flow covers efficiently supply flows for multiple function circuits. Piston outputs are grouped together in the cover, with various piston flow splits available in this ten-piston pump.

These pumps are also available with isolator valves, to separate one or more pistons from the main outlet. Up to ten independent flows are possible from these ten-piston pumps.

Contact the sales department for Split-Flow® options and availability.

FLUID RECOMMENDATIONS

Mineral Oil

A high-grade premium petroleum-based fluid should be used to assure long component and system life. The fluid should have a combination of anti-wear, demulsibility, rust protection, oxidation-resistant and foam-resistant properties.

Special Fluids

Various pump models are available for use with water-based fluids, diesel calibration fluids, phosphate ester fluids, machining coolant, brake fluid, various military fluids and other special fluids.

PF4300 Series pumps are compatible with a variety of water-based fluids. These models, which are specifically rated for use with low-lubricity fluids.

Some pump models may require reduced operating pressures when using low-lubricity fluids.

Because of the wide range of fluid characteristics, contact the sales department for a review of any application using non-petroleum based fluids.

Viscosity Specifications

Using fluid with the correct viscosity range is critical to achieving long component life.

Fluid conditions outside the "Optimum" range shown in the table may result in reduced pump output, requiring pressurized inlet conditions. For more information, contact the sales department.

Hydraulic Fluid Viscosity^①

| Pump Models | Operating | | | | Start-up ^② | | Optimum | | |
|--|-----------|-----|---------|-----|-----------------------|-----|-----------|----------|--|
| | Minimum | | Maximum | | SUS | cSt | SUS | cSt | |
| | SUS | cSt | SUS | cSt | | | | | |
| <i>Fixed Displacement Pumps:</i> | | | | | | | | | |
| PF500-10 | 52 | 8 | 1911 | 413 | 3706 | 800 | 98 to 324 | 20 to 70 | |
| PF1000-10 | 59 | 10 | 1911 | 413 | 3706 | 800 | 98 to 324 | 20 to 70 | |
| PF2000 | 59 | 10 | 1911 | 413 | 1911 | 413 | 98 to 324 | 20 to 70 | |
| PF2000 ^② | 34 | 2,3 | 1911 | 413 | 1911 | 413 | 98 to 324 | 20 to 70 | |
| PF3000-10 | 59 | 10 | 1911 | 413 | 3706 | 800 | 98 to 342 | 20 to 70 | |
| PF4000-30 | 34 | 2,3 | 1911 | 413 | 1911 | 413 | 98 to 324 | 20 to 70 | |
| PF4200-10 | 34 | 2,3 | 1911 | 413 | 1911 | 413 | 98 to 324 | 20 to 70 | |
| PF4300-11 | 31 | 1,5 | 927 | 200 | 927 | 200 | – | – | |
| PF6000 | 34 | 2,3 | 1911 | 413 | 1911 | 413 | 98 to 324 | 20 to 70 | |
| <i>Mechanical Variable Delivery Pumps:</i> | | | | | | | | | |
| PV4000 | 34 | 2,3 | 1911 | 413 | 1911 | 413 | 98 to 324 | 20 to 70 | |
| PV6000 | 34 | 2,3 | 1911 | 413 | 1911 | 413 | 98 to 324 | 20 to 70 | |
| <i>Hydraulic Variable Delivery Pumps:</i> | | | | | | | | | |
| PV6000 | 34 | 2,3 | 1911 | 413 | 1911 | 413 | 98 to 324 | 20 to 70 | |

① Fluid conditions outside the "Optimum" range may result in reduced output, requiring pressurized inlet conditions. Contact the sales department.

② Models with special mounting.

MINIMUM FILTRATION LEVELS

Pump inlet: 150 μ nominal;

Pressure or return line: 25 μ nominal.

While finer filtration levels than these are desirable and will result in longer component life, restricting flow to the pump inlet should be avoided. Minimum recommended inlet conditions must be maintained.

If a system component fails resulting in fluid contamination, it is important to drain and clean the reservoir, all lines, filter screens and all components. Refill with new fluid.

INSTALLATION AND OPERATION

Refer to separate Bulletin PSI.CB for general installation and operating recommendations.

That brochure includes information on mounting, shaft loading, sizing inlet pipe and hose, air bleed procedures and initial start-up. Guidelines for maintenance, repair and trouble-shooting are also included.

PV4000 SERIES

Typical Performance Curves

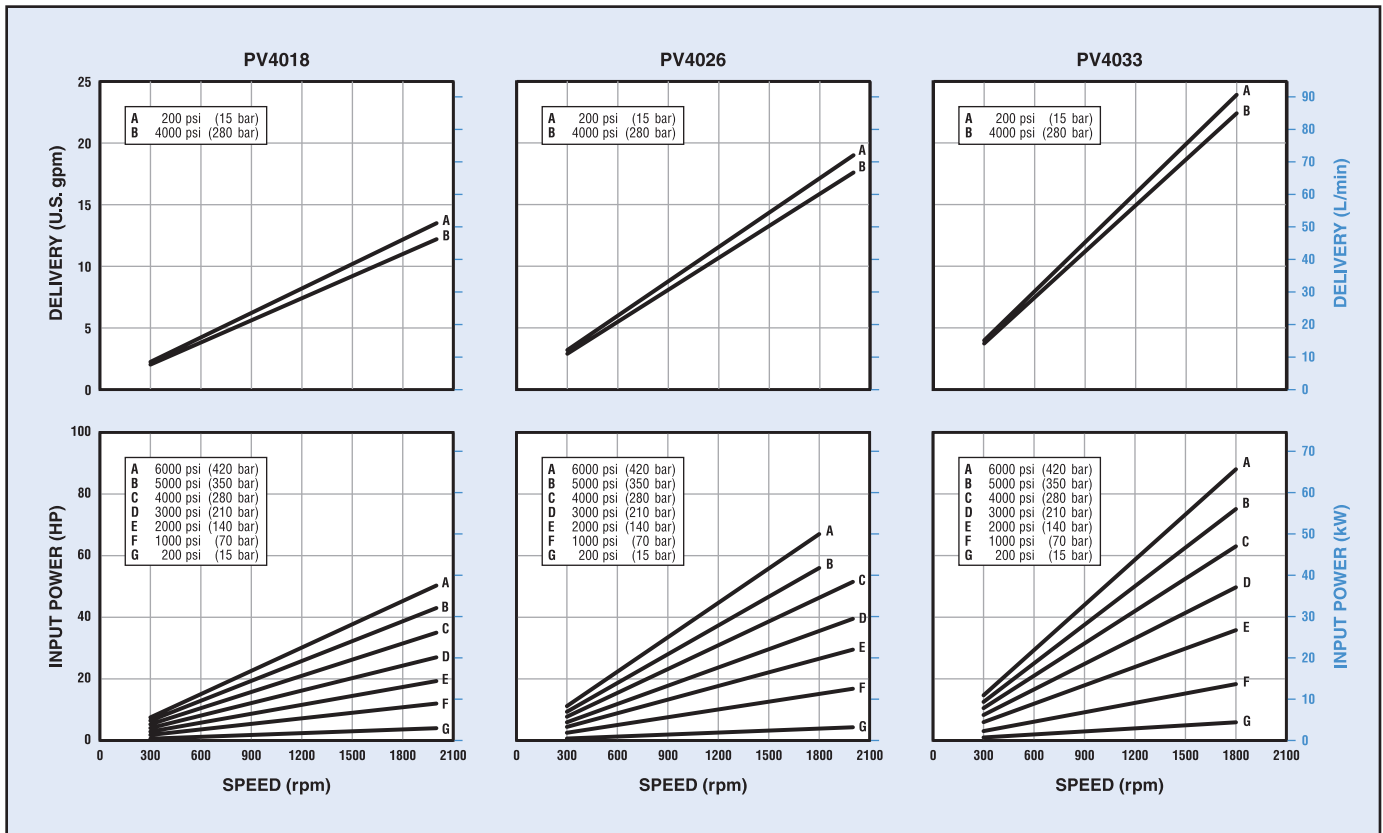

Typical performance curves are based on 100 SUS (20 cSt) mineral oil with pressurized inlet where required. Refer to the "Minimum Inlet Pressure" table on page 2.

INSTALLATION

All dimensions are shown in inches (millimeters in parentheses) and are nominal. See page 2 for optional spline shaft data.

Refer to Bulletin PSI.CB for general installation and operating recommendations.

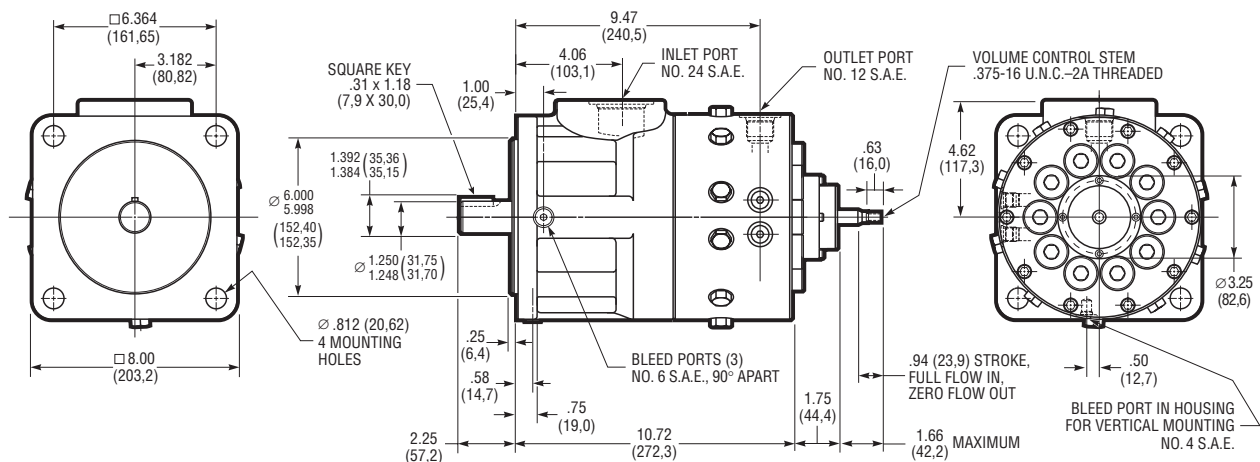

PORT DESCRIPTIONS

Dynex pumps are available with outlet ports suitable for use at various pressure ranges. Refer to the appropriate "Specification Table" or "Typical Model Code" to specify the required port.

Contact the fitting manufacturer to ensure the selected fittings are rated for the maximum pump operating pressure.

S.A.E. Straight Thread Ports

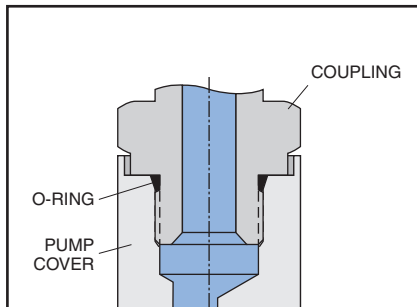

Typical S.A.E. Straight Thread port connection

The Straight Thread connection (S.A.E. J1926/1) is sometimes referred to as an S.A.E. O-ring Boss, or ORB. The port consists of a machined spotface surface, a tapered seal cavity and a straight thread port.

The fitting forms a seal by compressing the o-ring in the seal cavity with the underside of the flanged wrench flat. Some adjustable fittings, such as elbows and tees, use a locknut with a captive backup washer for compression.

S.A.E. Straight Thread ports are not recommended for operation above 8000 psi (560 bar). Also, the maximum pressure of pumps with No. 12 S.A.E. outlet ports may be limited by the pressure rating of the available fitting. Contact the fitting manufacturer for ratings.

Coned and Threaded Ports

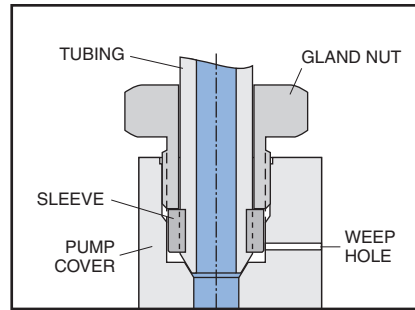

Typical Coned and Threaded port connection

High-pressure pumps are available with coned and threaded outlet ports, which use Autoclave Medium Pressure, Butech M/P, or equivalent fittings.

These fittings provide a metal-to-metal seal with an interference fit, not requiring an o-ring. The gland nut holds the sleeve and tubing against the cone surface.

A weep hole, visible on the outside of the pump cover, acts as an indicator of any abnormal leakage caused by system conditions (i.e., excessive pressure). It allows any fluid which does leak past the sealing surfaces to escape, preventing pressure build-up and possible damage.

British Standard Pipe Ports

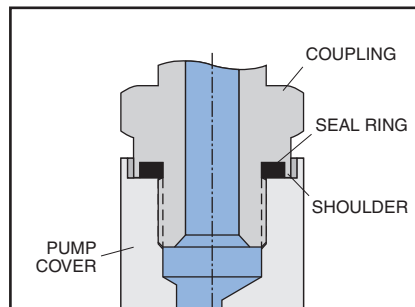

Typical port connection with British Standard Pipe (Parallel) fitting with shoulder

High-pressure pumps are available with flat face ports with British Standard Pipe (B.S.P.) parallel threads (BS 2779 or ISO 228), ideal for use on some European applications.

The fitting forms a seal by compressing a flat elastomer ring on a machined spotface surface. There are several sealing methods for these ports.

The recommended fitting has a recessed seal cavity formed by a shoulder on the underside of the flanged wrench flat (Voss "Peflex", Form B Shoulder Seal; or Parker Type E, "E0lastic" Seal; or equivalent).

B.S.P. ports are not recommended for operation above 10 000 psi (700 bar). Contact the fitting manufacturer, to ensure the selected fittings are rated for the maximum pump operating pressure.

S.A.E. 4-Bolt Flange Ports

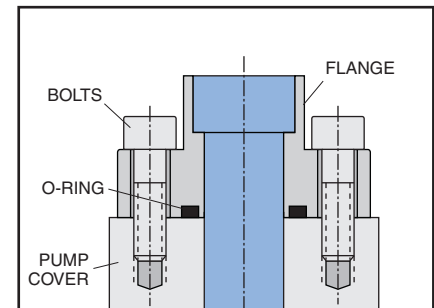

Typical S.A.E. 4-Bolt Flange port connection

Flange connections are often used for higher flows requiring larger diameter tubing. The port consists of an unthreaded port with four bolt holes in a rectangular pattern on a machined face around the port (S.A.E. J518).

A typical fitting consists of a flanged head with a welded tube and a captive flange with bolt holes. A seal is formed by an o-ring in the groove on the underside mounting surface of the flange head. As the flange bolts are alternately tightened, the o-ring is compressed between the flange head and the machined face on the pump.

To make mounting easier in tight spaces a two-piece split-flange is often used.